

PART No: TWAC-28-A-F

Flared alignment curbs are ideal for guiding lorries into the correct position in front of the loading dock, thus minimising damage to dock equipment, and ensuring correct alignment with any levelling equipment every time.

MATERIAL	Steel
WEIGHT	75.5 Kg Each
ESTIMATED LEADTIME	2 - 3 Weeks
FIXING TYPE	Above ground.
QUANTITY OF SALE	Pair

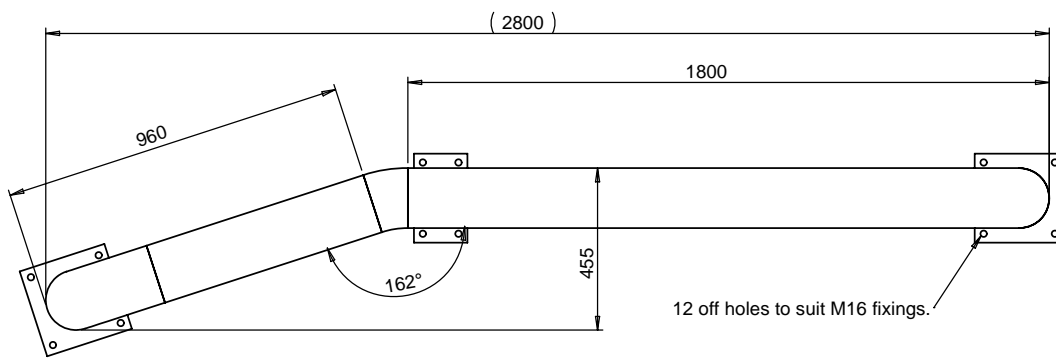
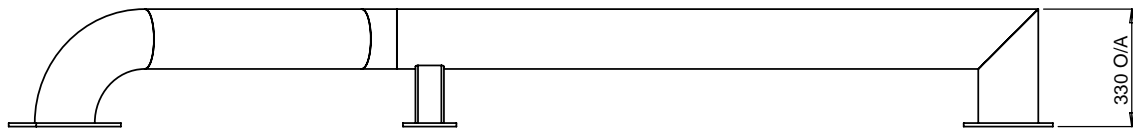
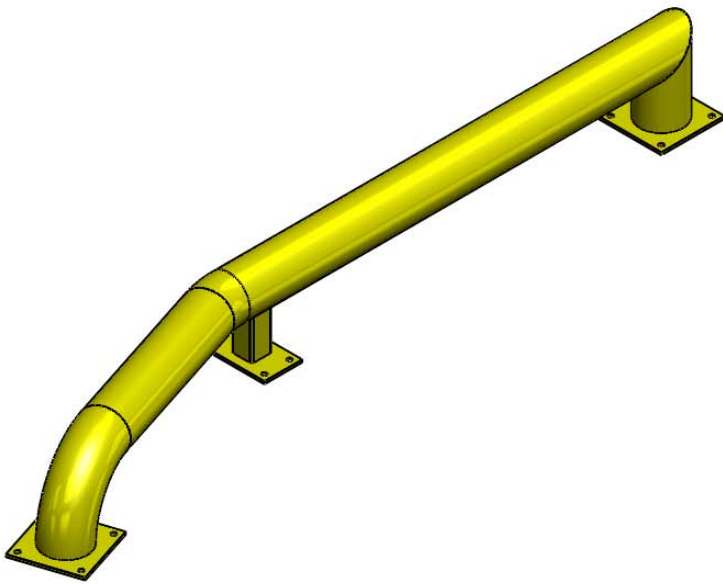

NOTE - For fixing into sound concrete only.

All dimensions shown are in millimetres and are intended for reference purposes only; exact product measurements may vary due to applied tolerances and methods of manufacture

